

REV	BY	DATE	DESCRIPTION

REVISION LOG

KANE INNOVATIONS
 GUARDIANS OF SAFE ENVIRONMENTS
 KANE SECURITY
 SERVING BY NAME

© 2021

© 2021

G-VAN-O
GALV. VAN GUARD - OPERABLE
REVEAL MOUNT

PROJECT NO.

DRAWN DATE
 09/15/2014

SCALE
 3/4" = 1' - 0"

SHEET
 E1

INFORMATION SHOWN ON THIS DRAWING IS PROPRIETARY AND THE SOLE PROPERTY OF KANE INNOVATIONS CORPORATION, AND IS NOT TO BE REPRODUCED, DISCLOSED, OR TRANSMITTED TO OTHERS FOR ANY PURPOSE NOT AUTHORIZED BY KANE INNOVATIONS CORPORATION.

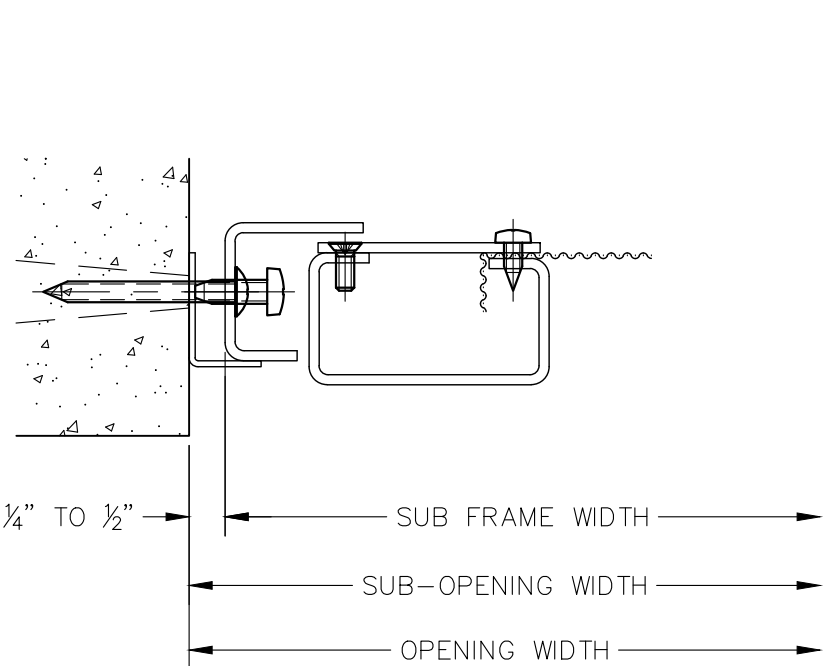

3 LEFT JAMB
SCALE: 6"=1'-0"

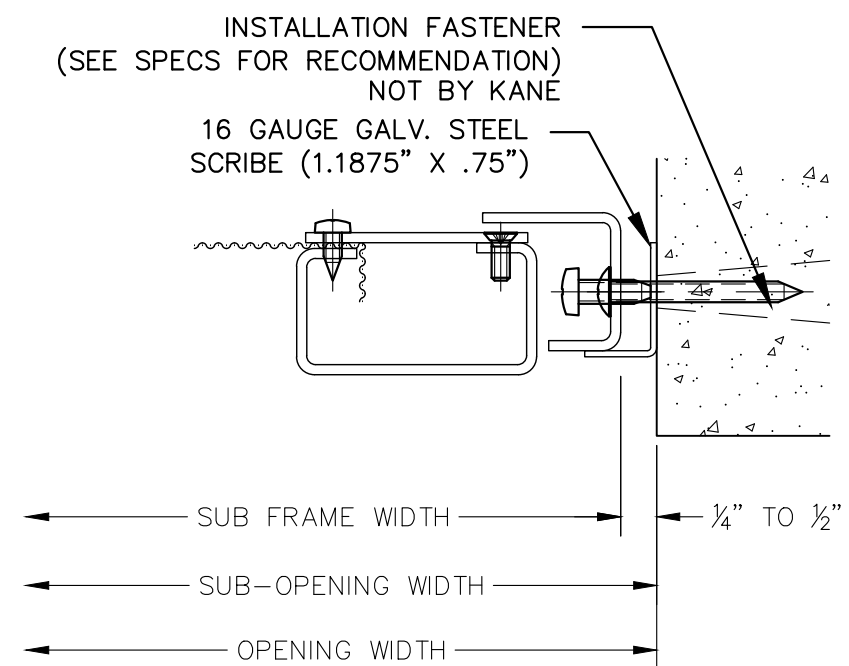

4 RIGHT JAMB
SCALE: 6"=1'-0"

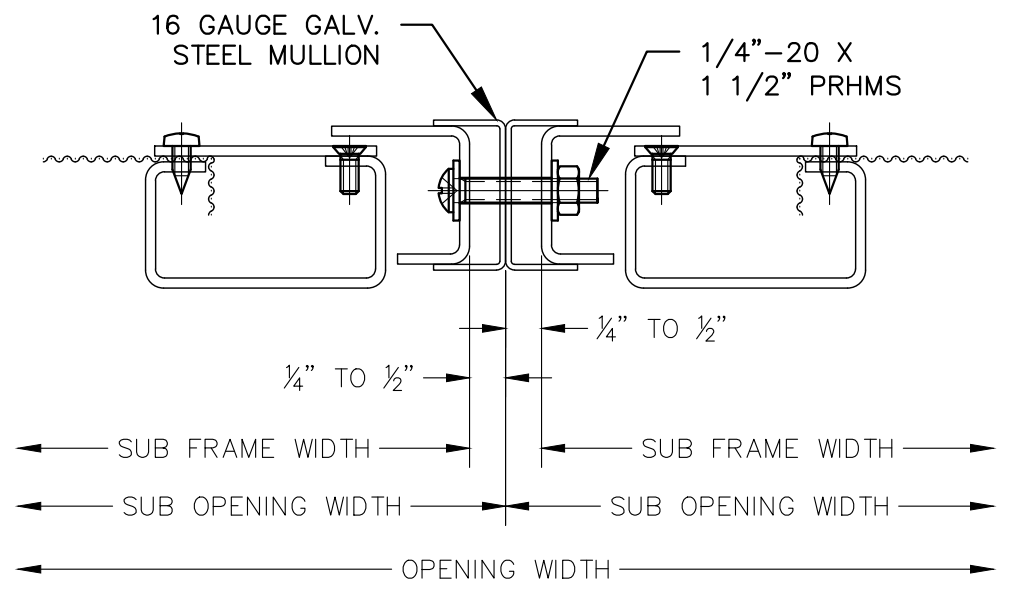

5 MULLION DETAIL
SCALE: 6"=1'-0"

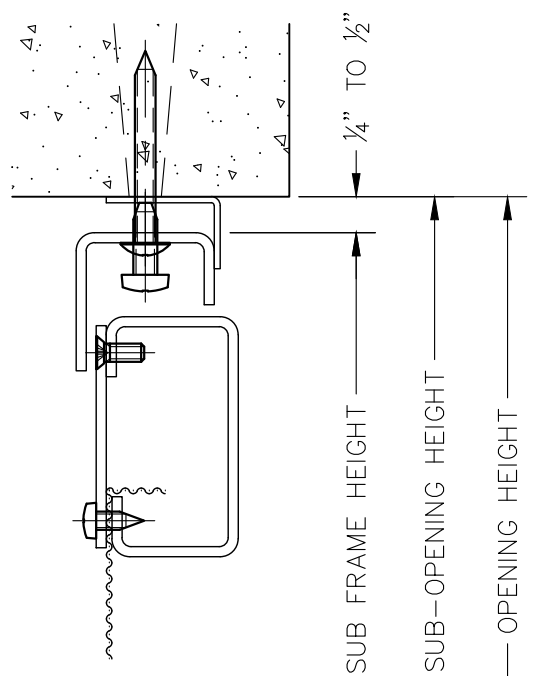

1 HEAD DETAIL
SCALE: 6"=1'-0"

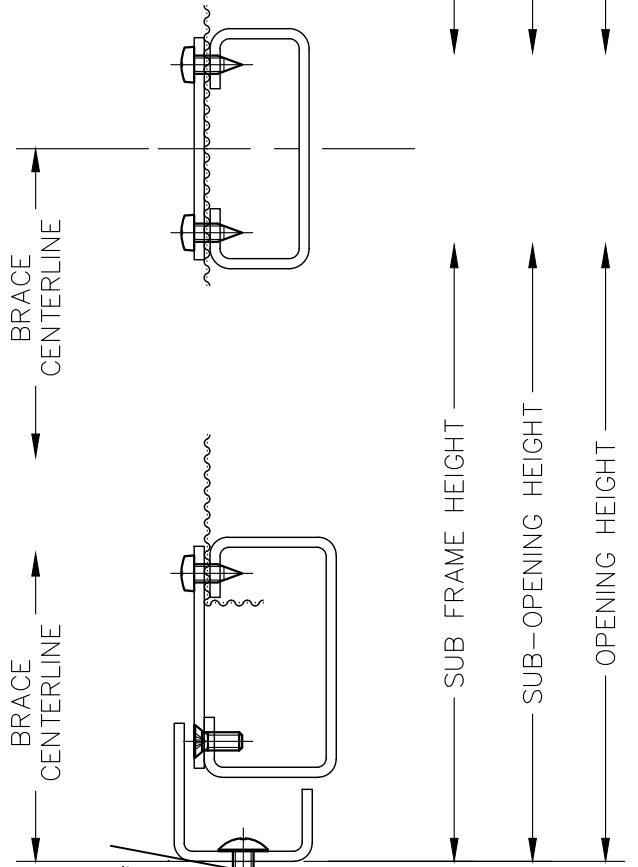

6 BRACE DETAIL
SCALE: 6"=1'-0"

2 SILL DETAIL
SCALE: 6"=1'-0"

REV	BY	DATE	DESCRIPTION

KANE INNOVATIONS
GUARDIANS OF SAFE ENVIRONMENTS
KANE SECURITY
FORMING BY KANE

© 2021

G-VAN-O
GALV. VAN GUARD - OPERABLE
REVEAL MOUNT

PROJECT	
PROJECT NO.	
DRAWN	DATE
	09/15/2014
SCALE	6" = 1' - 0"
SHEET	D1

INFORMATION SHOWN ON THIS DRAWING IS PROPRIETARY AND THE SOLE PROPERTY OF KANE INNOVATIONS CORPORATION AND IS NOT TO BE REPRODUCED, DISCLOSED, OR TRANSMITTED TO OTHERS FOR ANY PURPOSE NOT AUTHORIZED BY KANE INNOVATIONS CORPORATION.